

Gestionnaire de batteries pour Véhicules Récréatifs
 Batteries manager for Recreative Vehicules



- a) Positif+ Batterie du véhicule – Positive+ to vehicule battery
- b) Commun – Négatif - Ground
- c) Positif+, Alimentation Accessoires – Positive+ to Accessories
- d) Interrupteur démarrage – Marche/Acc – Run/Acc Switch
- e) Positif+ Batterie pour accessoires – Positive+ Accessory Battery

Introduction

Thank you for buying our product. The batteries manager for Recreational Vehicles (RV) has been developed by people using a small camper. While installing a secondary battery for accessories on a recreational vehicle, we realized it wasn't possible to buy a system of the shelf that would be easy to install and use that completely took care of the management of energy available for accessories. What you bought is the result of our experiences and researches. In addition, by buying this product, you contribute to improve the science of alternate energy sources since ÉnergiePlus, the company, reinvests the profits in researches to develop efficient and environmental energy solutions.

Product description :

This device, once installed correctly, will serve you with a reliable and efficient management to power your accessories. This module provides real-time estimation of energy still available for your accessories. Depending on its mode of operation, the manager module offers the following features:

- RUN / ACC Mode:

This mode is automatically activated when you turn ignition switch to ACC or RUN position. The module receives a signal from wire ACC / RUN (Blue).

In this mode of operation, if your engine is not operating and the alternator is not running, your accessories are powered **only by the primary battery** of the vehicle (one that is used to start the engine).

If your engine is running, the module periodically checks the voltage of the primary electrical circuit. When the alternator runs, the module detects the recharge the main battery. After two minutes recharging the main battery only, the module connects the secondary battery (that only powers the accessories) to the primary circuit for recharging.

In this mode of operation, as soon as you turn your ignition switch to the "OFF" position, the module is disabled and power to accessories is cut off.

- Autonomy Mode :

Autonomy mode is useful when you need to use accessories for a long time without restarting the vehicle. It is commonly called Camping Mode. To start the Autonomy module mode, press the « START » button and hold the button down until the status lights indicate power status.

In this mode of operation, the module manages the electricity needed accessories. First, it provides energy from the two batteries and then at a certain voltage level, the module disconnects the primary battery to ensure vehicle's restart.

Once the primary battery is disconnected from the accessories, the manager continues to power the accessories using only the secondary battery. The module cuts off power accessories when the battery reaches a threshold where continuing to power the accessories would damage the internal structure of the battery.

If the module is connected only to the primary battery, the management module completely cuts power to accessories at the right charge level to ensure vehicle's restart.

At any time during this mode of operation, it is possible to interrupt the management and stop powering the accessories by pressing the button « STOP/ FORCE »

- Force Mode:

This mode is activated when the module is not operating (off) and that the buttons « STOP/ FORCE » and « START » pressed simultaneously. This connects the primary and secondary batteries in parallel to power accessories without any management for approximately twelve to fifteen minutes. After this period, the module automatically cuts power accessories.

This feature is useful if you are using a device that consumes much power for a short time. In fact, when using an accessory that needs high current, voltage drop can bring sudden confusion to the module. It is useful in such situations to be able to tell the module that it is wished that it does not manage accessories during this period. The display of STATUS still indicates an estimate of the remaining power capacity.

It is possible that you need to use accessories for a short time or that you'll need to use accessories after the manager has reached the limits of safe discharge of batteries. In these cases, the "Force" mode is recommended. It is important to note that draining a battery beyond what the module allows can damage it. As this mode allows the module to further discharge the batteries, it is also possible the vehicle will not restart after this intervention.

Meaning of STATUS and INFO lights :

- STATUS lights:
 - GREEN : Your energy resource to power accessories is at it's best.
 - YELLOW : You still have about two thirds of the energy left to power your accessories.
 - RED : The manager is powering the accessories with the last third of it's full capacity..
- INFO lights :
 - ORANGE/Amber :
 - Lit : The manager is using the primary AND secondary batteries to power accessories.
 - Blinking : The manager is powering the accessories ONLY from the primary battery.
 - Not lit : The manager is using only the secondary battery to power the accessories.
 - GREEN (Recharge) :
 - Lit : The manager detected the recharging signal for the alternator. The primary battery is recharging.
 - Blinking : The manager is recharging the secondary battery from the primary circuit.
 - Not lit : The motor and alternator are not running.

Installing the manager:

The installation of the module **must be performed by a qualified person with the knowledge of electricity and power circuits.** The module must be installed in a accessible and visible location in order to be able to see statuses and operate it easily. The module must be installed in a cool place, away from direct sunlight as this will extend the life of the module and provides ease reading of LED indicators.

It is essential to protect the connections of the manager module with fuses that corresponds to the maximum current drawn by the accessories. Diagrams at the last page of this manual indicates you where to install the fuses. It is important to install the main fuses **as close as possible to the positive poles** of the batteries. Failing to properly install the fuses may expose you to fire hazards and will void your warranty.

This batteries manager for recreational vehicle is designed to sustain a continuous current of 20 amps at 12.5 volts. It can tolerate a maximum of 40 amps for short durations.

Here is the description and purpose of each connection cables for the installation of the batteries manager for Recreational Vehicle (RV):

Black Cable: This cable must be connected to the metal frame of the vehicle. This is the connection to the common negative (ground). This connection is used to power the manager and provide a reference point for estimating the energy available for accessories. Other electrical device should never be connected directly to this cable, as this can result in errors of estimation and instabilities of operation.

Red cable: This cable **MUST BE** connected to the positive pole of the primary battery. It is essential to install a fuse on this primary cable as close as possible to the pole of the primary battery.

Yellow cable: This cable is connected to the positive pole of the secondary battery. It is essential to install a fuse on this secondary cable as close as possible to the pole of the secondary battery.

White Cable: This cable carries the energy to accessories. This is the positive connection for the accessories. This connection cable provides energy to the fuses panel that distributes electricity to each accessories.

Blue cable: This cable tells the management module if the vehicle is running. Connect it to a point in the circuit of the vehicle that is powered only when the ignition switch is in the position ACC and RUN.

Troubleshooting :

| Problem | Question | Solution |
|--|--|---|
| The module doesn't operate at all. | Is the primary battery connected? The primary battery connection is essential to the functioning of the batteries manager. | Connect the positive lead of the primary battery to the PRI+ cable. |
| The module doesn't detect primary circuit's recharge or the module doesn't correctly estimate the energy left for accessories. | Is the installation of cables are very long? Too small gauge of wire? It is possible that improper installation causes loss of voltage. | For long wires installation, please use bigger gauge wiring. |
| | | |

Technical Specifications :

| | |
|---------------------------------------|-------------------------|
| Maximal power consumption : | 5 Watts |
| Maximum voltage : | 17 Volts |
| Maximum current : | 20 Amperes continuous |
| Ambient operating temperature range : | 0 to 40 degrees celcius |
| Dimensions (L X l X h) : | 10 cm X 3,7 cm X 5 cm |
| Weight : | 180 g |

Important facts about batteries :

Strength of a battery :

A lead-acid battery must be considered as a muscle. Each battery as it's own characteristics and must be respected. Here's a general rule to follow: Your battery powering the accessories must be able to provide energy during more than twenty hours without interruption. If the battery cannot provide that autonomy, you need to change the battery for a bigger capacity or add another one in parallel to reach over twenty hours autonomy. A battery that can power your accessories without being stressed will have a longer service life.

Battery's limit :

When a battery reaches the critical level of discharge, it continues to provide power to the circuit, but damages itself in order to maintain the current flow. It is best to avoid crossing this threshold, because when the battery reaches it, it got only 5% of its total energy left. The battery will continue discharging while damaging itself before being completely drained. This ill-treatment shortens the life of batteries. Using the battery manager for RV avoids critically discharging your batteries.

Batteries and winter :

The lead-acid batteries supply power to your accessories by electrochemical reactions. As in all chemical reactions, temperature plays an important role. It is clear that a battery can release energy more efficiently and quickly in warm temperatures. In very cold weather, the chemical reaction occurs more slowly. It is important to mention the lead-acid batteries contain water (acid) and can freeze very cold temperatures. When a battery freezes, its internal structure is substantially damaged by the formation of ice crystals. If you can not store your batteries in a warm place for the winter, make sure they are completely recharged because a battery fully charged is more resistant to freezing.

Warranty :

What is covered by warranty:

This product is manufactured from new parts and components, in accordance with industry standard practices. The warranty covers defects in materials and manufacturing.

The warranty period:

This warranty lasts for one year, starting from the date of purchase.

What is not covered by warranty:

This warranty does not cover damage caused by the negligence of the user, misuse or improper installation of this product, as well as modifications to this product. ÉnergiePlus is not responsible for any damage that may be caused to electrical circuits and devices connected to this batteries manager.

Warranty terms:

ÉnergiePlus will replace or repair (at its option) the defective product at no cost during this warranty period. ÉnergiePlus will use new or reconditioned parts(at its option) from various manufacturers to repair a defective product or to make a replacement product. If ÉnergiePlus repairs or replaces a product, its original warranty remains the same and will not be extended.

Claims under warranty:

You must present a proof of purchase to be entitled to the privileges of the warranty. In addition, the product must not have been opened, modified or altered without permission. To make a warranty claim, return this product to the store where you purchased it with a copy of your proof of purchase dated and legible or email us to support@energiepluslabs.com for more informations.



Schéma des connexions – Batterie du véhicule ET batterie des accessoires
Connections schematic – Vehicle battery AND accessory battery



Schéma des connexions – Batterie du véhicule seulement
Connections schematic – Vehicle battery only

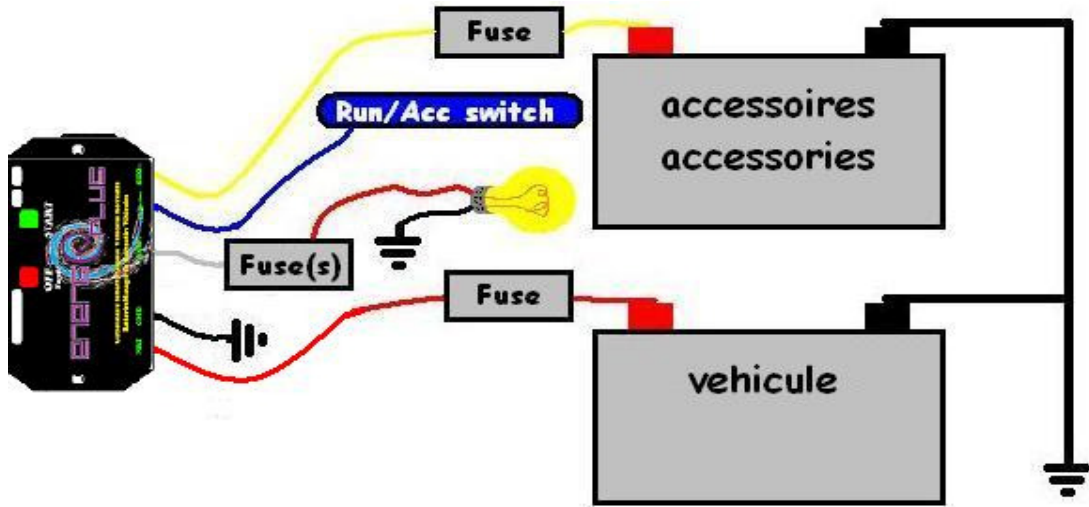
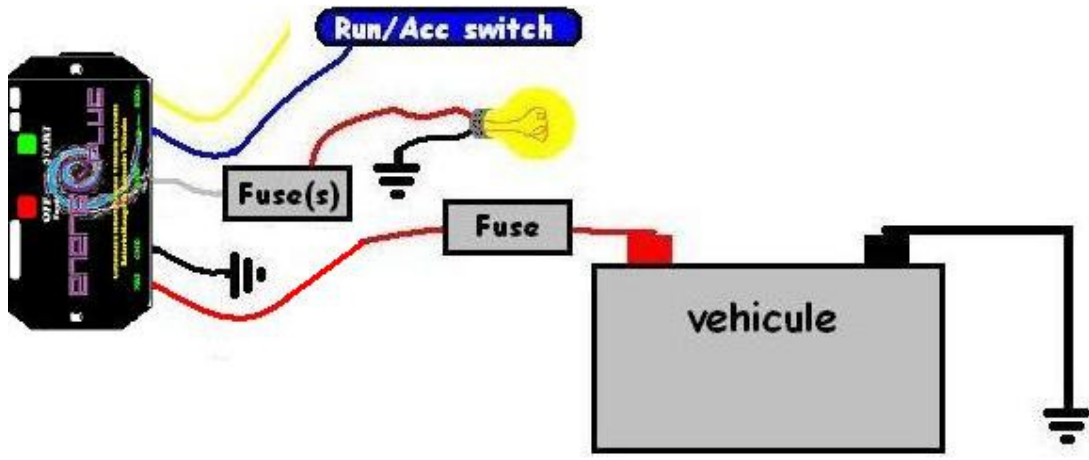
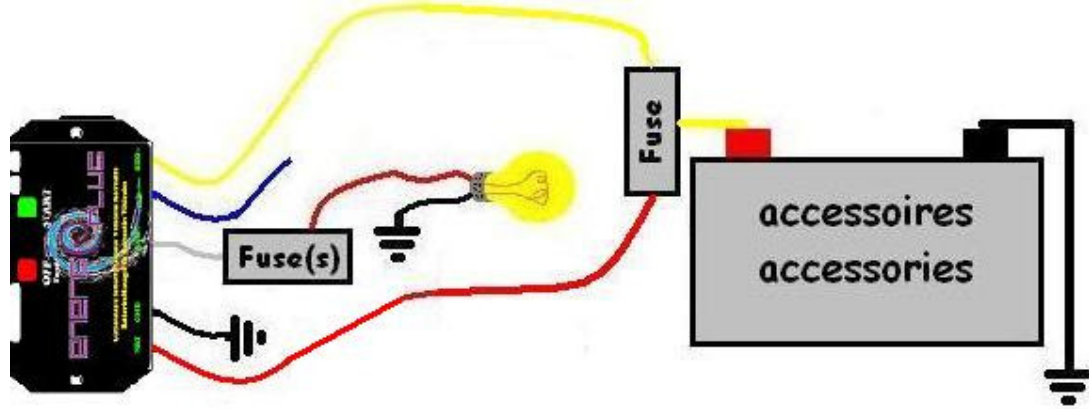

Schéma des connexions – Batterie des accessoires seulement
Connections Schematic –accessory battery only